

Model 1700L Live Pup Trailer Maintenance Manual



SECTION 3: MAINTENANCE

(Minimum Recommendations)

Inspections and Schedules

G & H Manufacturing has developed two inspection forms which indicate the items to be inspected and the frequency of the inspections. It is important for the life of the unit and for warranty purposes that both forms be used as indicated. The forms are as follows:

- Q1021 – Daily Driver Vehicle Inspection Report – CCR
- Q1024 – Preventative Maintenance Inspection Form – 150 HR, 1200 HR, and 2400 HR

A copy of both inspections is included with this manual.

Torque Specifications for Fittings (Ft.-Lbs.)(Min. – Max.)

SIZE	37° JIC	FLAT FACE “O” RING
1/4”	10-11	10-12
3/8”	17-19	18-20
1/2”	34-38	32-40
3/4”	70-78	65-80
1”	94-104	92-105
1 1/4”	124-138	125-140
1 1/2”	156-173	150-180

Pressure Settings

- Main Hydraulic Control Valve – 1900 at 1500 RPM

Grease Points

Apply Grease at the points shown in Figure 11 at the frequencies recommended in the Inspection Schedules. Recommended Grease: Heavy Duty EP Grease NLGI2.

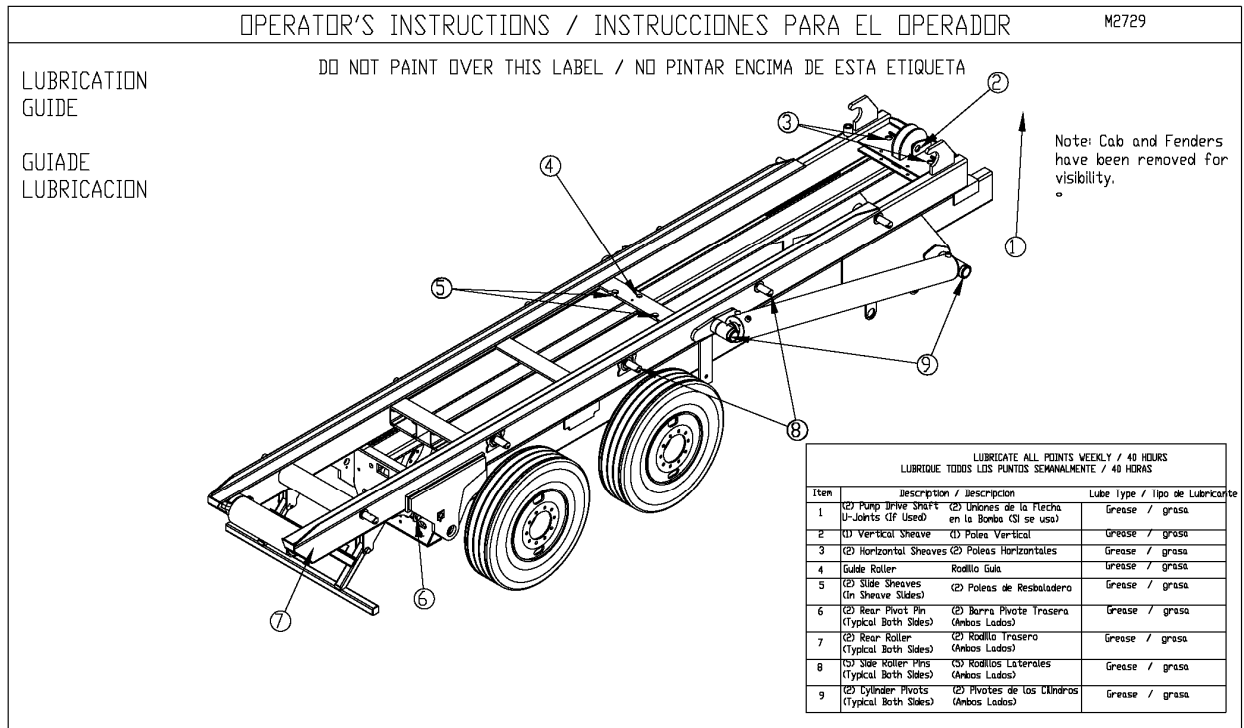

Figure 11

Hydraulic Oil

- Recommend ISO Grade 46
- Maintain Hydraulic Oil Cleanliness Level of ISO 18/15/13