



TBX50 Two Box Trailer



Since 1978, G&H Manufacturing has engineered exceptional products for the waste and recycling industry. We manufacture the #1 most requested hoist in the industry.

Innovative designs are combined with cutting edge technology and genuine craftsmanship, exceeding all industry standards and providing unsurpassed quality and assurance.

Standard cable transfer winch moves the cable hook back into position for loading a second container

Fully interchangeable Sheaves and Fenders



ICC Bumper folds as the Hoist is raised

All TBX Two Box Trailers come with two speed hand crank landing gear

Available Options

Drop in Stops
Air Lift Third Axle
Aluminum Tool Box 36"
Steel Tool Box 24", 36", or 48"
Machined or Polished Wheels
Aluminum or Steel Fenders

Standard Features

ABS Brakes
50,000 lb. Hoist
Ratchet Tie Downs
11R22.5 Radial Tires
Air Ride Suspension
Driver's Side Trailer Controls

Two Speed Landing Gear
Front and Rear Poly Fenders
6 in. X 79 in. Lift Cylinders IC
6 in. X 79 in. Reeving Cylinders IC
14,000 lb. Container Transfer Winch
All D.O.T. Lighting Mid-Turn Signals
25,000 lb. Axles 5 X 5/8 inch Wall

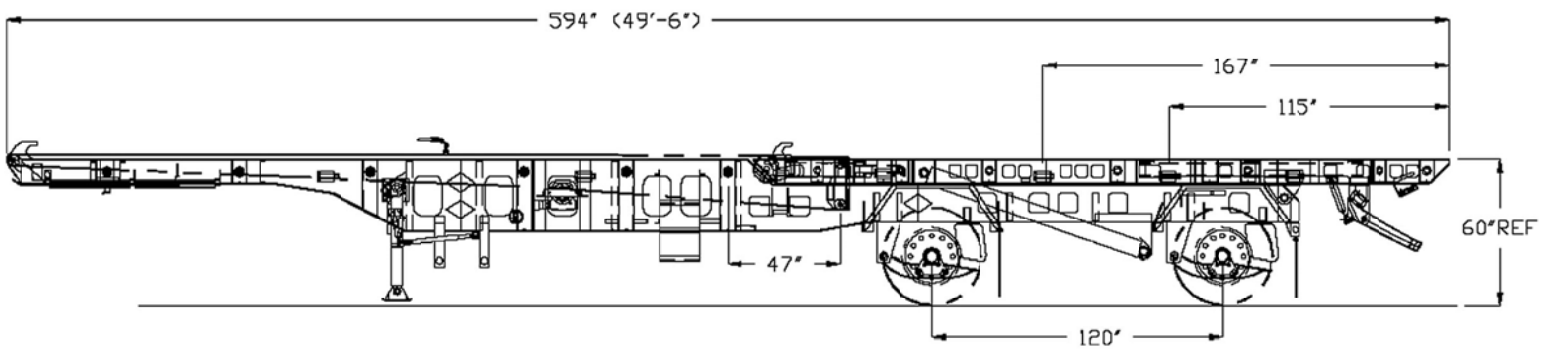

TBX50 Two Box Trailer Specifications

ABS Brakes
Air Ride Suspension
All DOT Lighting
Auto Suspension Lowering Valve
Axles Tandem 5 X 5/8 in. Wall 25,000 lb. Capacity
Mid-Turn Signals
11R22.5 Radial Tires
Poly Fenders Front and Rear
Five Interchangeable Sheaves
Ratchet Tie Downs - Two Pair with Handles
Trailer Controls - Driver's Side
50,000 lb. Hoist - Two 6 in. X 79 in. Reeving Cylinders
Transfer Container - One 14,000 lb. Winch
Two Speed Landing Gear

GH Manufacturing
 ISO Registered 9001:2000
 1015 Commercial Blvd. South
 Arlington, Texas 76001
 817-467-9883
 1-800-654-5291

