



Since 1978, G&H Manufacturing has engineered exceptional products for the waste and recycling industry. We manufacture the #1 most requested hoist in the industry.

Innovative designs are combined with cutting edge technology and genuine craftsmanship, exceeding all industry standards and providing unsurpassed quality and assurance.

Retracted to 32 feet



All EXT Trailers come with a Front Trolley Cylinder. This allows the container to move back and forth to adjust the weight of the load

Controls are set out from under the container for easy access while operating

Extended to 42 feet

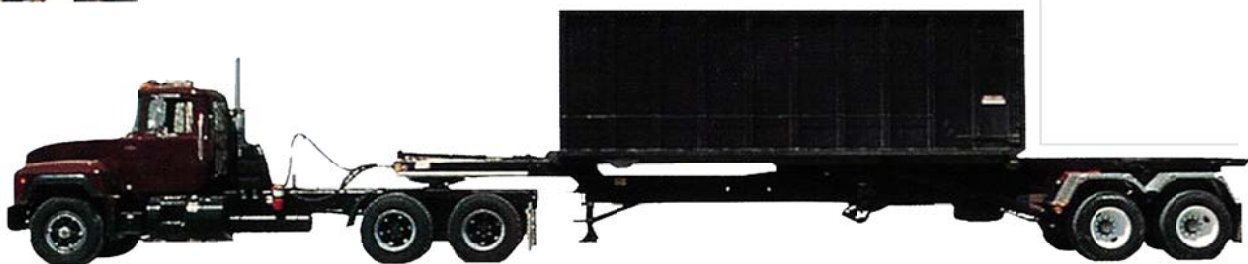

Available Options

Dead Lift
Air Lift Axle
Extendable Tail
Aluminum or Steel Fenders

Standard Features

ABS Brakes
Safety Prop
Mid-Turn Signals
Auto Slack Adjuster
11R22.5 Radial Tires
Air Ride Suspension
Front Carriage Assembly
Ratchet Tie Downs with Handle (2 pair)
Poly Fenders (interchangeable and replaceable)

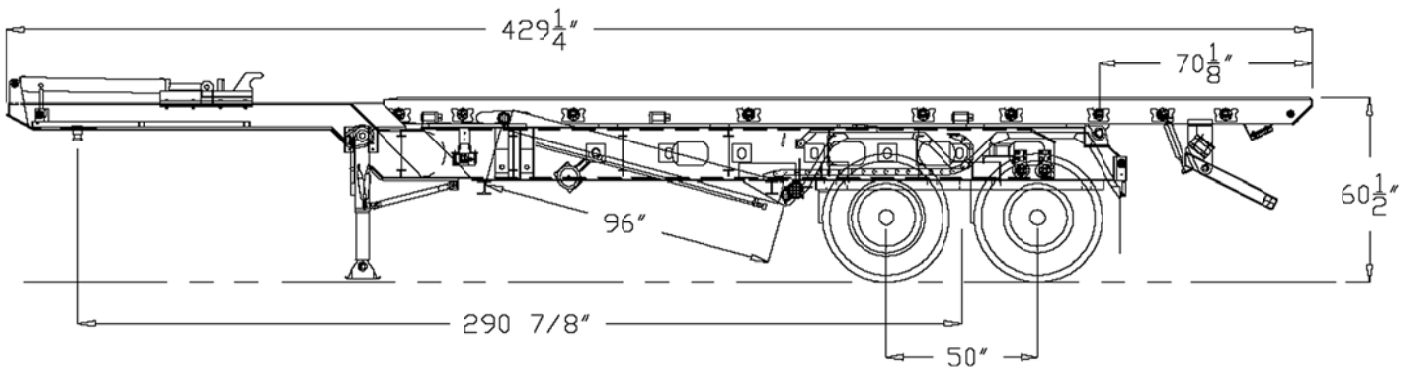

EXT Extendable Trailer Specifications

Cylinders, Reeving	6 in. Bore X 96 in. Stroke Single Stage, Double Acting
Cylinders, Tilt	6 in. Bore X 79 in. Stroke Single Stage
Front Container (transfers cylinder)	4 in. Bore X 48 in. Stroke Single Stage
Ratchet Tie Downs	Four Ratchet with Strap and Hook
Trailer Main Frame	16 in. 40 lb. Wide Flange I Beam
Front and Rear Fenders	Poly Fenders, Bolt-On and Replaceable

US Patent Number: 5183371

GH Manufacturing
 ISO Registered 9001:2000
 1015 Commercial Blvd. South
 Arlington, Texas 76001
 817-467-9883
 1-800-654-5291

