

Since 1978, G&H Manufacturing has engineered exceptional products for the waste and recycling industry. We manufacture the #1 most requested hoist in the industry.

Innovative designs are combined with cutting edge technology and genuine craftsmanship, exceeding all industry standards and providing unsurpassed quality and assurance.

Side Rollers incorporate Aluminum Bronze Bushings secured with bolts and collars



Standard, Heavy-duty, one piece Rear Roller or Quick-Change Rear Roller available

Interchangeable Fenders, Cylinders, and Sheaves

Heavy-duty steel Rear Hinge with 32" pin surface

Rear ICC Bumper automatically raises, as the hoist is raised

Enclosed Sealed Beam Lights mounted in rubber

Available Options

- Dead Lift
- LED Lights
- Wetline Kit
- Back up Alarm
- Extendable Tail
- Automatic Tarper
- Window Protector
- Tool Box 24", 36", 48"
- Fire Extinguisher Rack
- Quick Change Rear Roller
- Steel or Aluminum Fenders
- Ball Valve on Hydraulic Oil Tank
- Air Controls (Dual Lever or Joystick)
- Inside/Outside Rails with or without Rollers

Standard Features

- Hoist up Alarm
- Mid-Turn Signals
- Ratchet Tie Downs
- Poly Fenders - Interchangeable
- Side Mount Hydraulic Oil Tank
- Three Spool Valve Controls
- 32" Steel Rear Hinge

- Safety Prop
- Grease Fittings on all Wear Points
- In-tank Microglass Hydraulic Filter
- ISO 18/15/13 Oil Cleanliness Standard
- Air Shift P.T.O. with Direct Mount Pump
- Inside Cable and Outside Valve Control
- Hoist set up to add Third Axle with Single Tire

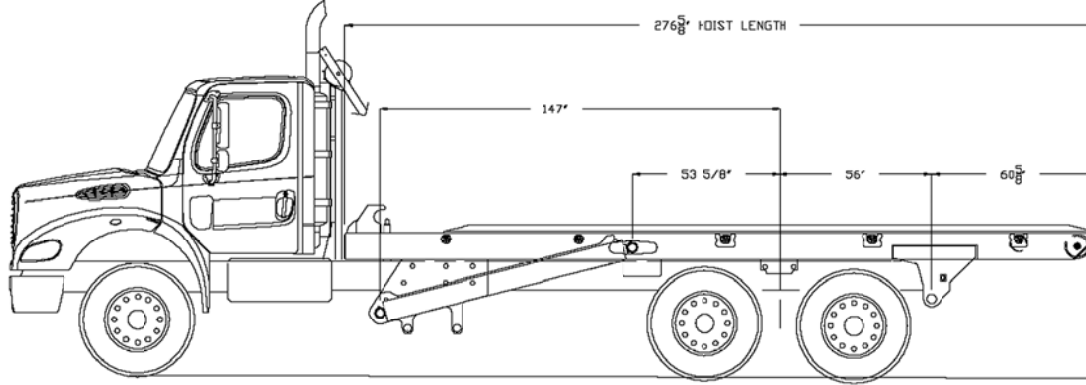

1500 Roll Off Hoist Specifications

| Model GH 1500 - 60,000 lb. Capacity (22 ft. box) | |
|---|--|
| Cylinders | Interchangeable lift and reeving cylinders 6 in. bore X 79 in. stroke single stage |
| Fenders | Poly replaceable and interchangeable |
| Air Shift PTO | With direct mounted pump |
| Hydraulic Tank | 50 gallon capacity, side mounted steel |
| Frame | 10 in. X 4 in. X 1/2 in rectangular tubing |
| Lights | Enclosed sealed beam lights mounted in rubber |
| Controls | Cable inside and outside of cab |
| Outside Rollers | 4 in. O.D. X 3 3/4 in. long with Aluminum Bronze Bushings |
| Sheaves | 10 in. Diameter with Aluminum Bronze Bushings for longer life |
| Rear Hinge | Heavy-Duty Steel with 32 in. pin surface |
| Grease Fittings | At all wear points |
| Lift Capacity | 50,000 to 60,000 lb. |
| Dump Angle | Approximately 50 degrees |
| Operating Pressure | 1900 PSI |
| Pump | 66 GPM at 1500 RPM |
| Valve | Multiple Stack - 4 Way Sections |
| Filter | 100 GPM in-tank return line |
| Cycle Times | 34 Seconds |
| Rear Hold Down | Ratchet Tie Downs |
| Wear Strips | 1/2 in. X 3 in. bar |

| Model GH 1560 - 60,000 lb. Capacity (22 ft. box) | |
|--|--|
| The following specifications are the ONLY differences between the 1500 and 1560 Roll Off Hoists | |
| Cylinders | Interchangeable lift and reeving cylinders 7 in. bore X 79 in. stroke single stage |
| Cycle Times | 39 Seconds |

